

B² audio

MODEL: Quota MKII

Product id:QUOTAD12



Quota

OWNER'S MANUAL



Foreword

We congratulate you with your decision to purchase our revered niche amplifiers. Every product developed by **B²** implements the keystones of our company philosophy; Optimum sound reproduction within its range, **Better Bass** & high performance. These elements will enable you to reproduce music the way you prefer.

Our amplifiers features a unique design, a variety of applications & highest possible efficiency combined with a clean analytical sound.

To obtain the full potential of the amplifier, it is strongly recommended & necessary to upgrade the stock electrical system in order to operate correctly & minimize failure. It is therefore essential to read through the whole manual to ensure optimum operation.

Installation can preferably be carried out by an authorized **B²** dealer.

Visit us at: www.b2audio.com & www.facebook.com/b2audio for further info & updates. Interested in competing? As a proud industry member of dB Drag Racing & IASCA you can easily get started. Visit www.termpro.com & www.iasca.com for information.



Better Bass

Better Bass is our philosophy of adding something extra. Keep in mind that continuous exposure to SPL above 100 dB can seriously damage your hearing. Today's high power auto sound systems can easily produce SPL over 140 dB. Enjoy your music with sense.

Table of contents

1. Design features	3	3.1 Installation considerations	5
2. Panel layout	4	3.2 Power connectors	5
3. Installation	5	3.3 Wiring layout	6
		4. Troubleshooting	7

1. Design features

Quota

Circuit Configuration	HI-EF Class D Mono
Frequency Response	: 10Hz ~ 300Hz
Signal to Noise Ratio	: 93dB
Input Sensitivity	: 6V ~ 0.2V
Crossover	: 12dB / Oct
Low Pass Crossover Range	: 30Hz ~ 300Hz
Subsonic Crossover	: 10Hz ~ 60Hz
Bass Boost @ 45Hz	: 0 ~ 12dB
Remote Control	: Optional
Phase shift	: 0 ~ 180°
Damping Factor	: 250<
Power Terminal gauge	: 4 ga
Fuse Rating	: 90A
Operating voltage	: 10V ~ 16V
Dimensions (WxHxL)	: 9.84" x 2.23" x 10.63"

All features are subject to change in the continuing effort to improve the products without notice.

Specifications

Continious output power rating (RMS)

Quota

Power @ 4 Ω
400 W x 1

Power @ 2 Ω
700 W x 1

Power @ 1 Ω (14,4V < 1% THD)
1100 W x 1

Power @ 4 Ω
450 W x 1

Power @ 2 Ω -
750 W x 1

Power @ 1 Ω (14,4V < 3% THD)
1200 W x 1

Specifications (detailed)

- 1) The *Quota* operates stable @ impedances of minimum 1Ωmono.
 - Running the *Quota* at these impedances sets requirements to ventilation & the battery system.
- 2) The amplifier has a 4 stage advanced protection circuit;
 - Thermal protection, Voltage sensors, DC offset & short circuitry via speaker outputs.
- 3) The *Quota* utilizes a double sided SMD pcb & high current mosfet switching devices in both the in- and output stage.
- 4) Awired remote level control is optional for the amplifier.
 - This unit will enable remote gain adjustment.
 - For more advanced features like selectable bass frequency, boost level & gain, the *Better Bass Remote* (optional) can be used.
- 5) The crossovers of the *Quota* are variable 12 dB/octave filters for both low pass & subsonic.

2. Panel layout

Quota

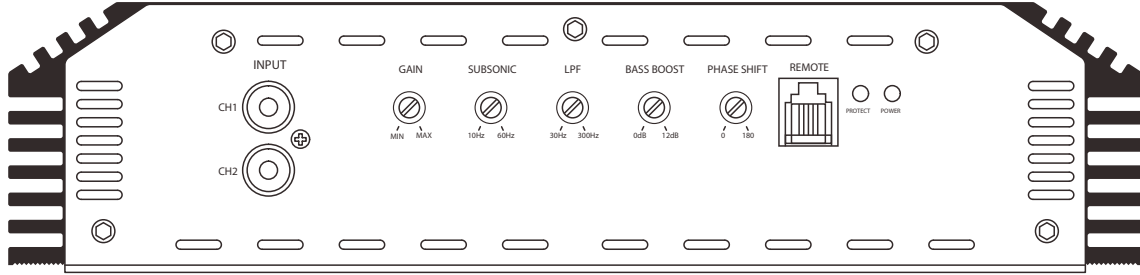

INPUT

Signal input from the head unit. A minimum level input of 0.2V is essential for correct operation.

POWER & PROTECTION INDICATOR

Power LED, Blue-lit shows correct operation. Protect LED, Red-lit shows general malfunction, faulty connection or thermal protection.

GAIN (6V~0.2V)

Matching of the output voltage from the head unit's RCA line-outs to the input section.

SUBSONIC FILTER (10Hz~60Hz @ 12dB/Oct)

Adjusts the cut off point to for the subsonic filter within the crossover's range.

LOW PASS FILTER

Adjusts the cut off point for the low pass filter within the crossover's range.

BASS BOOST

Variable bass boost with 0~12dB @ 45Hz.

PHASE SHIFT

Adjustable phase correction with 0~180°

REMOTE LEVEL CONTROL PORT

Connection of external level control. (The *Better Bass Remote* can be connected for additional features).

Power connetors

Quota

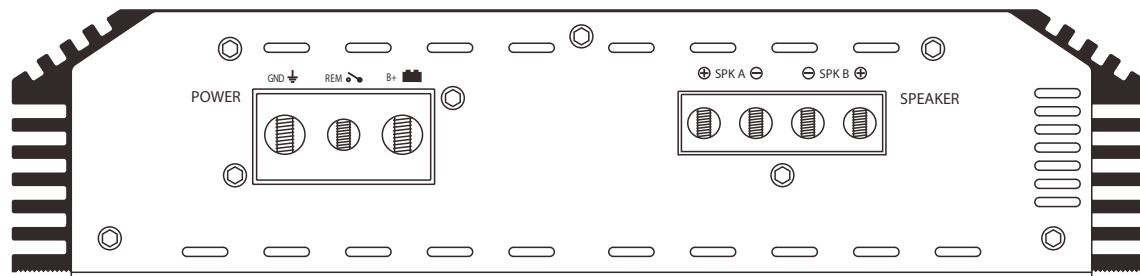

GND (GROUND CONNECTION)

For connection to the chassis' ground. For optimum performance 4 gauge cable is recommended.

+12V (POWER CONNECTION)

For connection to the positive terminal of the battery (+12). For optimum performance 4 gauge cable is recommended.

REM (REMOTE)

Connect to switched +12V from the head unit.

SPEAKER OUTPUTS

Amplifier connection to the loudspeaker. Minimum speaker cable is 12 gauge. Minimum impedance for the *Quota* is 1Ω.

3. Installation

3.1 Installation considerations

If you choose to install the amplifier by yourself, please read the owner's manual carefully.

Before you start your installation, please take all steps into consideration.

If in doubt, please go to www.b2audio.com for authorized distributors / dealers that will be able to configure your set up.

Preparation

Disconnect the negative (-) battery cable before mounting or making any connection.

Check the battery and alternator ground (-) connection.

Make sure they are properly connected and free of corrosion.

Before selecting a mounting location for the amplifier, please take cooling and safety into consideration.

The amplifiers have been designed with a heat dissipation heatsink with horizontal fins.

In order to avoid excessive heat from the amplifier, it is recommended to find a mounting location that allows for vertical positioning of the heat sink fins. Avoid areas with excessive vibration, such locations can over a longer period of time cause the amplifier to malfunction!

For safety purposes, install the amplifier in a dry and well ventilated location and make sure no cables or other harness of the car is interfaced with the mounting location or will present a hazard to the car's cable, control cables, fuel lines/tanks, hydraulic lines or other components of the vehicle.

3.2 Power connectors

12V (Power connection)

Before mounting the amplifier, disconnect the negative (-) wire from the battery to protect any accidental damage to the amplifier or the audio system.

The *Quota* is equipped with 4 AWG power and ground terminals.

Connect the power cables to power terminal labeled as + 12V.

The *Quota* uses external fuses. The correct rating is 90A.

Connect one end of the fuse holder to the power cable and the other end of the fuse holder to the positive battery terminal within 20 cm of the same cable.

This fuse location will protect the system and the vehicle against the possibility of a short circuit in the power cable.

Make sure that the fuses and the fuse holder is adequate for the desired application.

GND (Ground connection)

Locate a secure grounding connection as close as possible to the amplifier.

Make sure the location is clean and provides a direct electrical connection to the chassis of the vehicle.

Connect one end of an equal sized cable as the positive cable to the location of ground

It is important that the ground cable is as short as possible, but no longer than 75 cm at maximum.

Run one end of the cable to the grounding point.

Run the other end of the cable to the mounting location.

Connect the ground cable to the terminal labeled as GND.

REM (REMOTE CONNECTION)

Run a remote turn on cable from the switched + 12V source.

This may be a toggle switch, a relay, the source unit's remote output cable or power antenna trigger cable.

Connect the remote turn on cable to the power terminal labeled as REM.

3.3 Installation

+12V, GND, REM connection chart

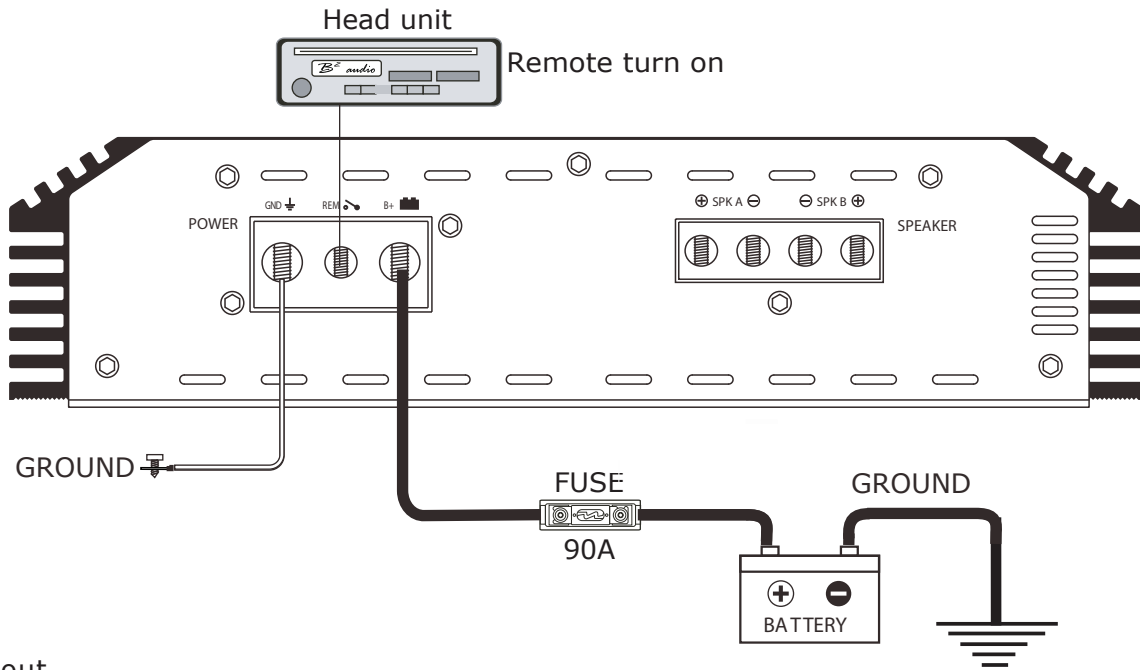

Wiring layout

We recommend using 12 AWG speaker cables to obtain increased performance. Run 12 AWG speaker cables from your speakers to the amplifier's mounting location. Keep the speaker cables separate from the power cables and the amplifier's input cables. Use grommets where the cables have to penetrate the vehicle's chassis. Connect the speaker wires according to the terminals on each speaker. Strip 3/8" of insulation of the end of each cable and twist the cables strands together tightly. Make sure there are no stray strands that might touch other cables or terminals and cause a short circuit. Crimp spade plugs over the cable ends or tin the ends with solder to provide a solid terminal. Connect the cable ends to the amplifier as shown in the speaker wiring diagram.

Quota

Speaker wiring diagram

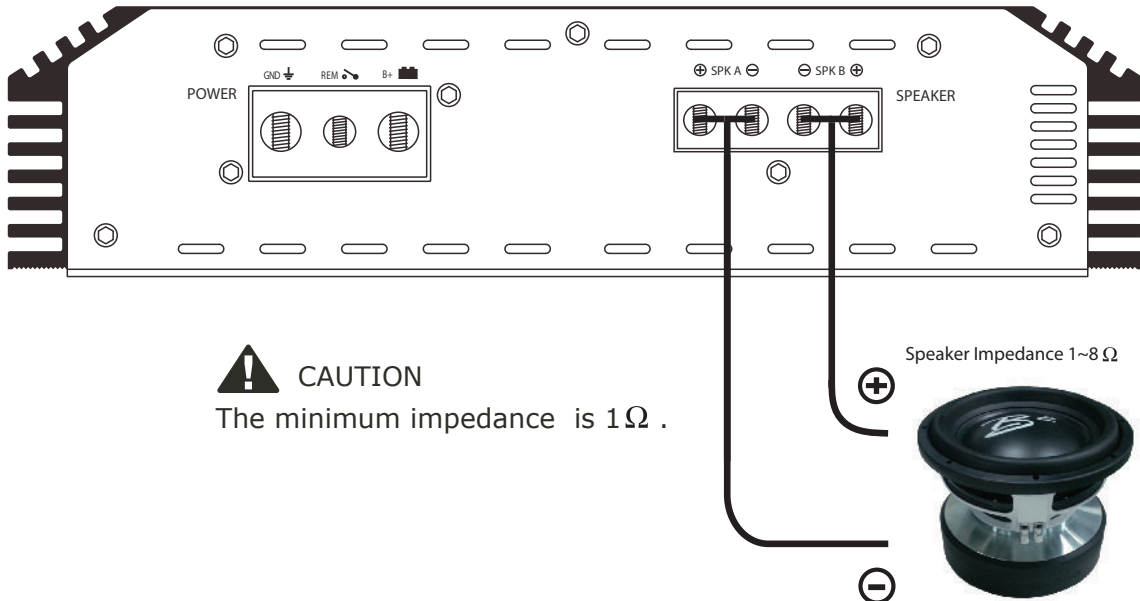

CAUTION
The minimum impedance is 1Ω .

Caution
The Quota is not to be Linked / Strapped. Severe damages may occur if used in such a configuration. Attempts of link / strap / bridge mode will void the warranty!

4. Troubleshooting

The protection circuits of the amplifier prevents severe damages from faulty conditions & improper use. The protection indicator will switch on due to short circuit connection & speaker overload, thus the amplifier will be turned off. Prior to inspecting the occurred problem, turn all levels down & all power off, then carefully check the installation for wiring mistakes, shorts or faulty ground (GND). If the amplifier shuts down due to excessive heat, the protection indicator will not light; please allow time for the unit to be cooled off. Before removing your amplifier, refer to the list below and follow the suggested procedures step by step. If not at ease, contact an authorized installer which can assist you.

AMPLIFIER DOESN'T TURN ON

- Measure voltage on the +12V terminal.
- Ensure that the remote terminal has min. 13.8V DC remote connection.
- Recheck the ground (GND) connection. Inspect the in-line fuses.
- Check the protection LED is not on.

PROTECTION LED IS LIT ONCE THE AMPLIFIER IS TURNED ON

- Check shorts on speaker wires.
- Disconnect the speaker cables and reset the amplifier. If the protection LED is still lit, then the amplifier is defective.

FUSE BLOWING

- Measure the speaker impedance & that it is in accordance with the configuration.
- Inspect the power cable for shorts along with vehicle chassis.

OVERHEATING

- Measure the speaker impedance & that it is in accordance with the configuration.
- Check speaker shorts.
- Ensure airflow around the amplifier is sufficient & that the amplifier is not installed in areas of excessive vibration.

AUDIO OUTPUT INSUFFICIENT - DISTORTED SOUND

- Ensure that the gain settings on the amplifier is matched with the output level of the head unit.
- Adjust the head unit volume.
- Check speaker shorts.
- Adjust the crossover frequencies in accordance with the setup.
- If no output at all, check the RCA connections & the cable itself.

TURN ON THUMP

- Disconnect the signal input to the amplifier, then turn it on and off.
 - a) If the noise is cancelled, then connect a delay turn on module on the REM wire running from the source unit to the amplifier.
 - b) Use another 12V source for REM lead to the amplifier. If the noise is cancelled, use a relay to isolate the amplifier from the turn on thump.

HIGH HISS-ENGINE NOISE IN SPEAKERS

- Ensure that all signal transferring wires (RCA, speaker cables etc) are kept separately / away from the power and the ground wires.
- Bypass all electrical components between the Head unit and the amplifier. Connect the Head unit directly to the amplifier's input. If the noise is eliminated, the unit bypassed is the one causing the noise.
- Remove the existing ground wires for all electrical components installed. Ensure that the point of ground is 100% metal which has been grinded free of rust, paint etc.
- Replace the ground cable from the OEM battery / alternator and ensure it is grounded accordingly.
- Test the battery and alternator load (can be carried out by a professional). Ensure that the vehicle's electrical system is in a good condition, this includes distributor, alternator, spark plugs / wires, voltage regulators etc.

B² audio

Feel free to visit us at: www.b2audio.com & at facebook; www.facebook.com/b2audio

Bz

Sweet Like Danish

