

GAS
AUDIO POWER

MAD USER MANUAL



MAD B1

B1-112VS / B1-212VS

MADE TO PLAY LOUD

WE PLAY LOUD!!

We know what you want. You want it LOUD, and that is exactly what we do, what we live for. Vibrations, gut-punches and straight up loud music - that's what makes us tick. We won't dress up in fancy words or claim to be something we're not. We are the NO BULLSH!T car audio brand!









Every single product with the GAS logo on it is born out of passion, the same that has driven us for two generations and that will keep us rolling up to your neighbourhood, winning and pushing the limits for many generations to come!

It's up to you to choose your own level of loud, and if you don't like what we do that's OK. You are welcome back when you've had your first true GAS experience. We don't exclude, we don't judge and we do not make up any excuses for who we are.

We are GAS and we are proud to be LOUD!

GAS

TABLE OF CONTENT

 SAFETY.....	3
 UNPACKING.....	4
 DIMENSIONS.....	4
 SPECIFICATIONS.....	5
MAD B1-112VS.....	5
MAD B1-212VS.....	5
 FEATURES.....	6
Absolutely MAD.....	6
Made to play loud.....	6
A lot of bass.....	6
Optimized enclosure.....	6
 HOW TO.....	7
Install pre-loaded enclosure.....	7
 TROUBLESHOOTING.....	10
No power/sound.....	10
Distortion.....	10
 WARRANTY & DISPOSAL.....	11
 THE GAS WORLD.....	12



SAFETY

PLAY LOUD & SAFE. Read through this information, follow the instructions and save the manual for future usage and reference.

Make sure to pay attention to the instructions when you see this symbol: 

Do not expose your new loaded enclosure to excessive damp or moisture. If the enclosure/subwoofer is exposed it might result in electric failure, shock or damage to the product. Servicing is required when the product has been damaged in any way and/or doesn't operate normally. Refer all servicing to qualified service personnel only.

Keep the cables inside the vehicle separate from sharp edges or components that may be affected or take damage. Follow the recommended cable sizes and always use high quality cables and accessories. Even if you're eager to put the enclosure to use – take no shortcuts when installing the cables, make sure that all connectors are protected and secured.

Do not drill any holes without checking what lies beneath, and don't cut anything without making sure that no important components risk being damaged.

To avoid potential injury from enclosure movements, the pre-loaded enclosure must be securely fastened in the vehicle on a suitable location.

There is a first time for everything, if you need help – ask a friend or contact your local GAS AUDIO POWER dealer/installer.

We want you to experience your product's MAD sound, but we don't want you to injure yourself or others. Use common sense, respect high pressure levels and volume, and follow your local laws and regulations.



UNPACKING

Unboxing your new MAD product is an experience, make sure that the enclosure and all the accessories are included in the packaging:

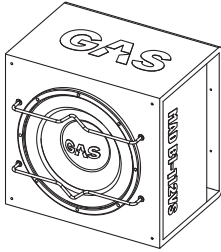

Loaded enclosure
(1 pc)



Slot Port Plug
(1 pc)

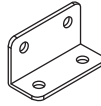

Brackets
(2 pcs)



Manual
(1 pc)



Screws
(10 pcs)

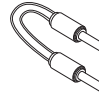

Jump cables
(2 pcs)



Feet
(4 pcs)

 Jump cables only included with B1-212VS

DIMENSIONS

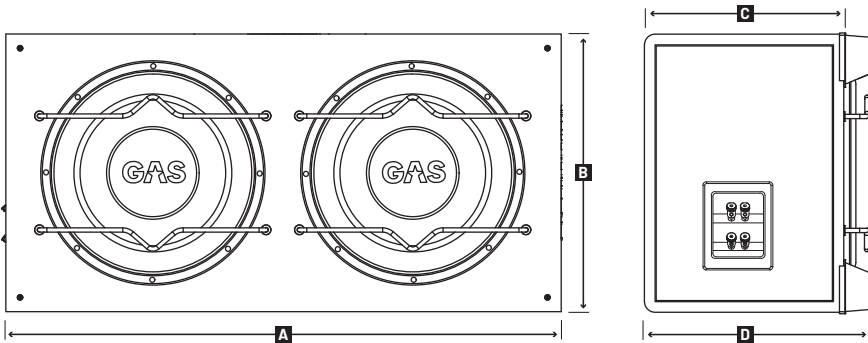

	A	B	C	D	
B1-112VS	390	390	280	322	mm
B1-212VS	780	390	280	322	mm

SPECIFICATIONS

Below you'll find the specifications that has been checked and tested in our workshop. The specifications aren't directly connected with the sound pressure in the vehicle, and shouldn't be used as the sole indicator for comparison with other enclosures. The MAD B1 enclosures are loaded with MAD S1 subwoofers (see product specifications below).

MAD B1-112VS	
Component	Pre-loaded Enclosure
Size	1x12" (300mm)
Nominal Impedance	4 Ohm
Power RMS	300W
Power MAX	600W
Volume	32 L
Weight	12.1 KG
F3	47 Hz
FB	40 Hz

MAD S1-3004	
Component	Subwoofer
Size	12" (300mm)
Nominal Impedance	4 Ohm
Power RMS	300W
Power MAX	600W
Freq. response	27-200Hz
Voice Coil	2" (51mm) PCW
Cone	IMPP
Dustcap	3D IMPP
Basket	M2 Steel
Magnet	Ferrite
Suspension	Rubber

MAD B1-212VS	
Component	Pre-loaded Enclosure
Size	2x12" (300mm)
Nominal Impedance	1 / 2+2 / 4 Ohm
Power RMS	600W
Power MAX	1200W
Volume	67.5 L
Weight	22.8 KG
F3	47 Hz
FB	40 Hz

MAD S1-3002	
Component	Subwoofer
Size	12" (300mm)
Nominal Impedance	2 Ohm
Power RMS	300W
Power MAX	600W
Freq. response	27-200Hz
Voice Coil	2" (51mm) PCW
Cone	IMPP
Dustcap	3D IMPP
Basket	M2 Steel
Magnet	Ferrite
Suspension	Rubber

FEATURES

ABSOLUTELY MAD

The MAD B1 enclosures are built to play LOUD. Really LOUD. Those awesome vibrations are what drives us to create impressive enclosures loaded with our subwoofers. Solid construction keeps everything together when the volume stays up, and MAD just keeps going. It is not about doing things the polite way. It's about bass, the MAD way.

MADE TO PLAY LOUD

We want you to be LOUD. The MAD B1 enclosures come pre-loaded with the MAD S1 subwoofer, built to take a beating. The IMPP cone is tough, stays in shape and keeps playing when things get wild. For the MAD B2-212VS enclosure, we have borrowed jump cables from the MAX series and a 4-pole terminal to make impedance matching easy. Choose between 1 or 2 plus 2 or 4 Ohm impedance options. Hook it up and let it rip. Be LOUD, be PROUD.

A LOT OF BASS

MAD is all about bang for the buck. That has always been the deal. The rigid, oversized square enclosure adds strength and helps keep the bass on track when the power hits. Give it some juice and it does exactly what you expect. Big bass, big attitude.

OPTIMIZED ENCLOSURE

Life in the trunk can be rough. And this enclosure is built to handle it, with protective bars and custom feet for flexible positioning. To give you more adjustment options, we have included a new feature: a Slot Port Plug. The SPP lets you choose between having a sealed or vented enclosure to adapt the character of the bass for you. You decide if you want the bass tight or aggressive. So get out there, play LOUD and show off your MAD lifestyle.

HOW TO

INSTALL PRE-LOADED ENCLOSURE

Before installing your brand new pre-loaded enclosure, make sure that you have everything you need. Have the right tools ready, and make sure that you have the necessary knowledge/skill to perform the installation properly. Preparation and knowledge is crucial!

The MAD B1-112VS enclosure use a 4 Ohm voice coil, while the B1-212VS enclosure use 2 Ohm voice coils. Since the enclosures are pre-loaded with MAD S1 subwoofers, the installation is very simple. Just connect it with your amplifier and get ready for LOUD bass!

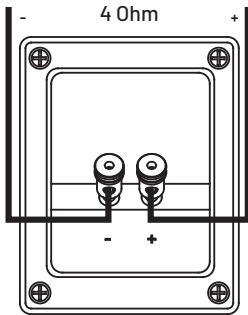

MAD B1-112 connection

The MAD B1-212VS enclosure has 2+2 Ohm impedance as its standard configuration, but it can be adjusted to 1 or 4 Ohm. It is important to know the limits of your amplifier to optimize its performance. You can vary the impedance by altering the wiring configurations by using the included jump jables. Choose the wiring diagram below that corresponds to the impedance stability of your amplifier.

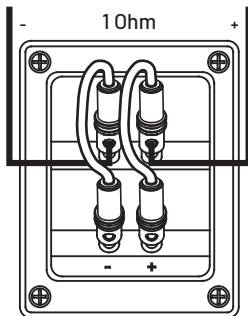

**parallel connection
(with jumpers)**

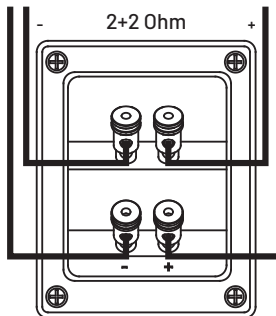

**singular connection
(no jumpers)**

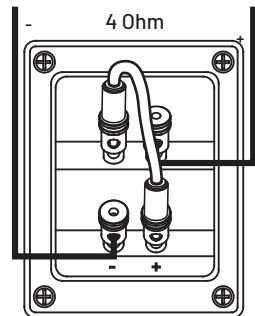

**serial connection
(with jumper)**

HOW TO

INSTALL PRE-LOADED ENCLOSURE



Make sure that the enclosure doesn't move around while driving, use the included mounting brackets and screws to securely fasten it in position.

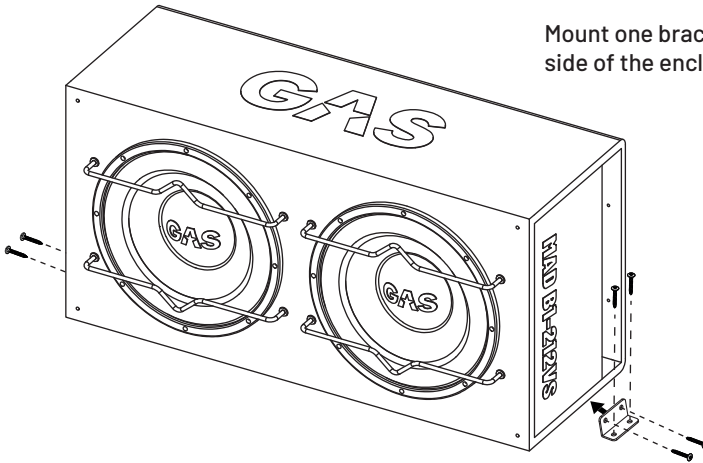

Mount one bracket on each side of the enclosure.

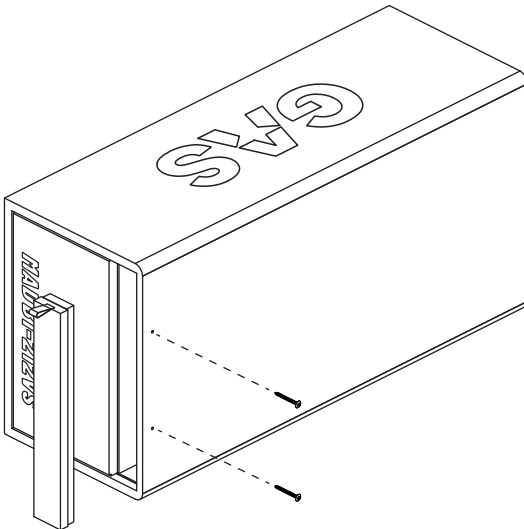

The versatile Slot port plug, SPP, lets you choose between sealed or vented operation, ensuring you get the perfect bass response tailored to your preferences. To make the enclosure sealed: Unscrew the 2 screws on the back side of the enclosure. Place the Slot Port Plug in the enclosure's port on the side and use the 2 longer screws included in the packaging to secure it. To make the enclosure vented, remove the loose Slot Port Plug from the enclosure's port and leave the shorter screws in the enclosure.

HOW TO

INSTALL PRE-LOADED ENCLOSURE



On the MAD B1-112VS and B1-212VS enclosures four special designed feet have been pre-mounted. With the feet on the enclosure you can aim the subwoofer downwards or in any other direction you prefer. If you wish to remove the feet you can follow the steps below:

Unscrew the 4 screws in each corner located in the subwoofer feet.
Remove the feet and reuse the screws to fill the screw holes. (see illustration below).

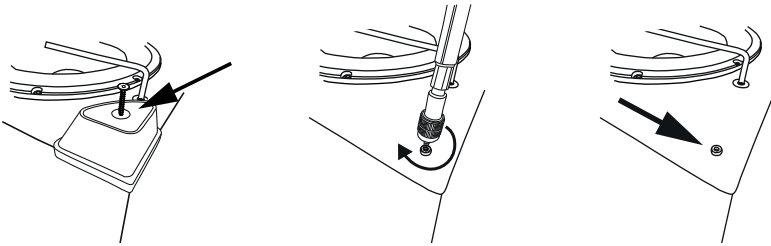

TROUBLESHOOTING

NO POWER/SOUND

Check the enclosure/subwoofer to make sure it isn't damaged. If your pre-loaded enclosure doesn't get any power, the most common issue is either in the wiring or in the amplifier. Use a multimeter to measure the amplifier's voltage on the +12V terminal and the remote signal terminal. Make sure that you have a negative ground connection. Check the built-in fuse (if there is one) on the amplifier. If there's no power coming through - control the fuse on the power cable. If the fuse is intact you should check all of the wiring to ensure cable integrity.

DISTORTION

Start by looking over the enclosure/subwoofer so there's no damage or connection issue with the wiring. Check the speaker cables to make sure that the polarity isn't reversed on one channel. Check the settings on the amplifier, make sure that the gain/level function is set according to the amplifier's instructions. If your amplifier has a boost function, lower its effect or turn it off.

When all of the above has been tested/looked over, and all is as it should be but the pre-loaded enclosure still has no power/sound or other problems, consult your local GAS AUDIO POWER dealer/installer

WARRANTY & DISPOSAL

This product is covered by warranty, depending on the conditions in the country where it's sold. If the pre-loaded enclosure is returned for service, please include the original dated receipt (or a copy) with the product. Make sure that the enclosure is packaged properly and secured, preferably in its original packaging.



The crossed-out wheeie bin symbol means that the product, literature and packaging included must be taken to separate collection at the end of their working life. Don't dispose of these products as unsorted municipal waste: take them for recycling. For info on your nearest recycling point, check with your local waste authority.



This product has been granted with the CE certification mark to show that the product follows the health, safety, and environmental protection standards for products sold within the European Economic Area (EEA).



GAS Audio Power products comply with the relevant provisions of the RoHS Directive for the European Union. In common with all Electrical and Electronic Equipment (EEE) the product shouldn't be disposed of as household waste. Alternative arrangements may apply in other jurisdictions.



GAS Audio Power is a global partner of the European Mobile Media Association, an organization that focus on promoting the custom made mobile media installations to consumers.

THE GAS WORLD

You've entered the world of GAS. We aim to please, and we've made sure to have products made for you. No matter what stage of the LOUD-addiction you might find yourself in, there is a GAS product to fill your need.

MAD

Just starting out? The MAD series is made to play LOUD and to be the express lane to a no bullsh!t sound system that will make sure everyone can hear you coming!

MAX

The MAX series holds products made to deserve the center stage. Powerful, heavy duty and designed to be noticed. We made NO COMPROMISES because we know that you wouldn't accept it.

CMP

The CMP series has been developed for the crucial seconds when the dB-counter starts to tick. All CMP products have hand-picked, high quality, COMPETITION GRADE components and they are specially designed to withstand an awesome amount of power.



THANKS FOR JOINING GAS AUDIO POWER!



GAS
AUDIO POWER

GAS AUDIO POWER and SHAKY are registered trademarks by Winn Scandinavia AB and is protected by relevant laws and jurisdictions such as Copyright and Trademark laws.

Winn Scandinavia AB | Idrottsvägen 37, 70232 Örebro, Sweden | www.winnscandinavia.com

Winn Scandinavia AB reserves for possible typos, factual or numeric errors that may have been printed on any products, package designs, user manuals and/or other included accessories.



GAS
AUDIO POWER